



Parts Included:



4D Arm Pad Plate



Fixed/1D Arm Pad Plate

Tools Required:

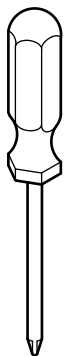

T-20 Torx Driver

Steps:

4D Arm Pad Support Plate Removal

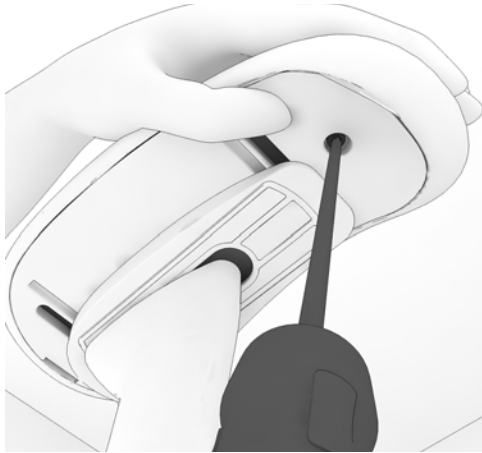

1. Using philips T20 torx bit remove the front arm pad bolt.



2. Lift up the arm pad and slide it off.

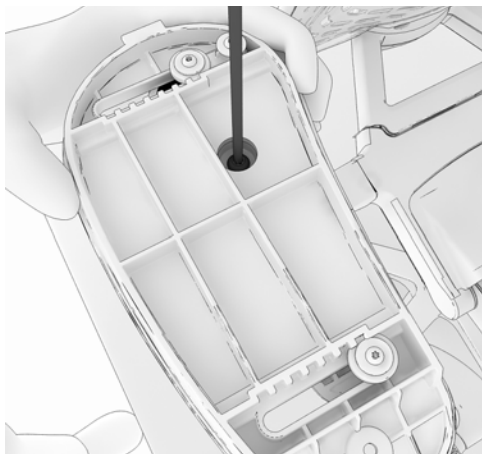

3. Using a T20 torx bit remove the single screw in the center of the arm pad support plate.

Note: slide the arm pad support plate to gain access to the screw.

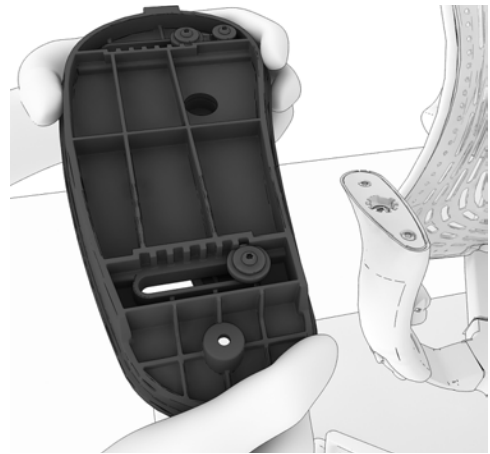

4. Arm pad support plate removed.

HermanMiller

Part no. 1BBSF4 rev D.

© 2014 Herman Miller, Inc. Zeeland, Michigan. Printed in the U.S.A.
©  Herman Miller, Mirra 2 are among the registered trademarks of Herman Miller, Inc.

Illustrations and specifications are based on the latest product information available at the time of publication. The right is reserved to make changes in design and specifications at any time, without notice, and also to discontinue products.

1D & Fixed Arm Pad Support Plate Removal

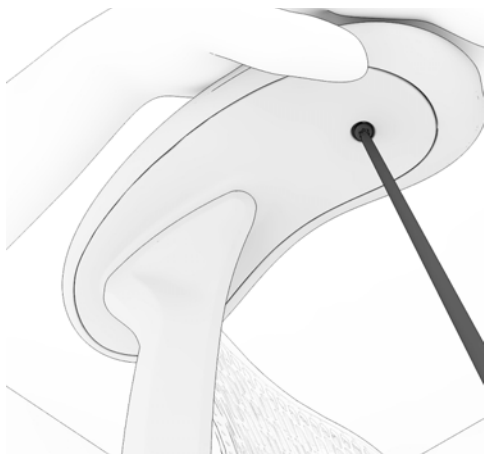

5. Using philips T20 torx bit remove the front arm pad bolt.

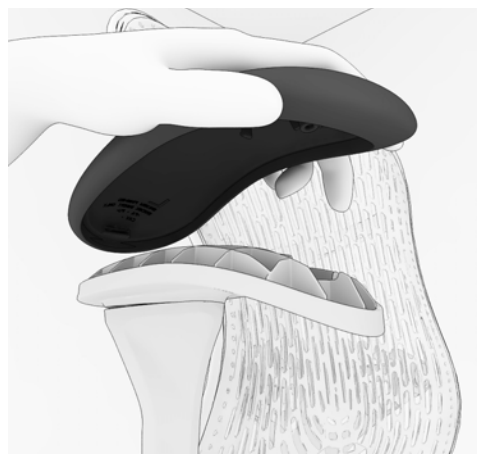

6. Lift up the arm pad and slide it off.

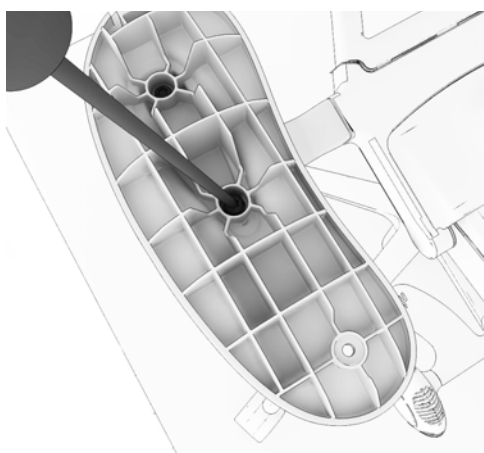

7. Using a T20 torx bit remove the two screws from the arm pad support plate.

Note: slide the arm pad support plate to gain access to the screw.

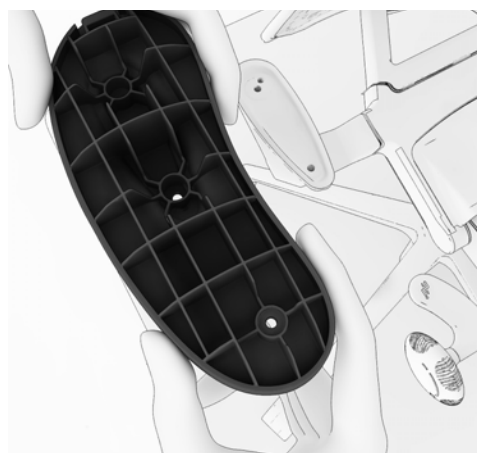

8. Arm Pad Support Plate removed.

Re-Assembly Steps:

4D Arm Pad Support Plate Installation



9. The 4D Arm Pad Support Plate is keyed. The key on the plate must match the key in the Arm Support.

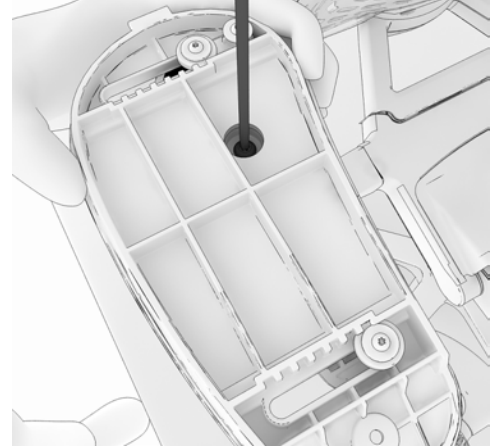

10. Reinstall the attachment bolt using T20 torx bit, tighten to 20 in/lbs

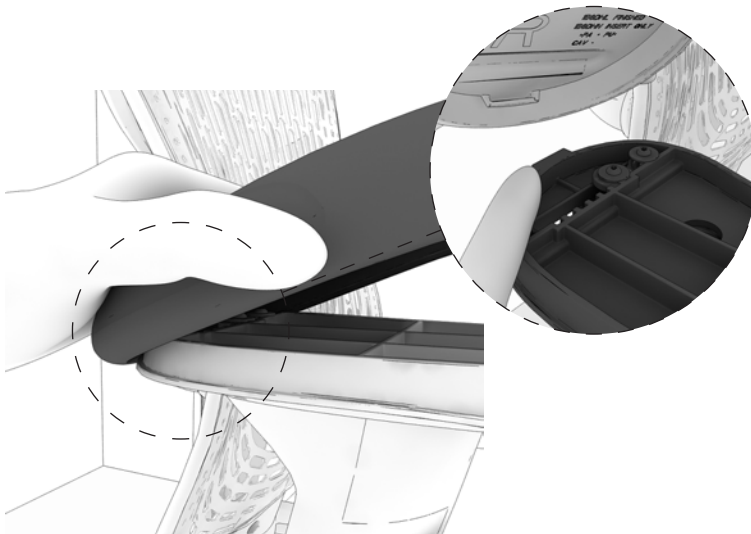

8. Hook the slot at the back of the arm pad into the tab on the arm plate and rotate the arm pad down.

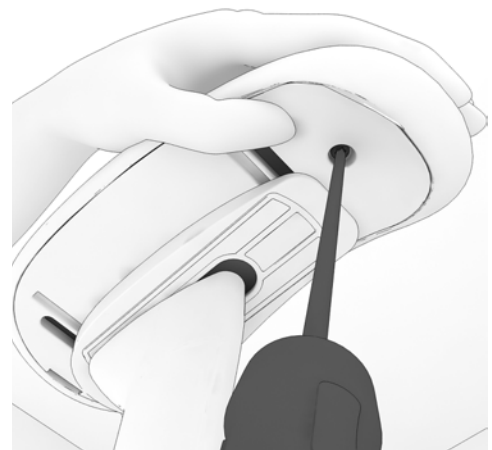

9. Torque to 15 in/lbs.

1D & Fixed Arm Pad Support Plate Installation

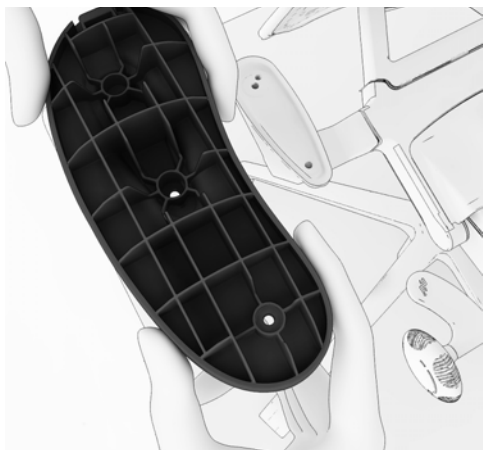

11. Position the arm plate.

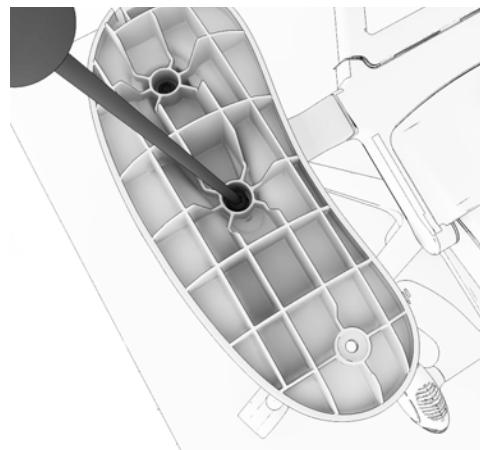

12. Reinstall the two screws and tighten to 20 in/lbs.

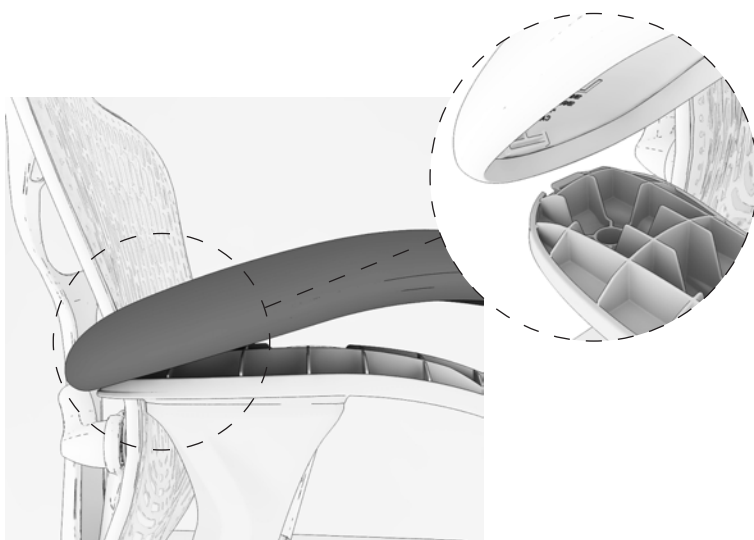

13. Hook the slot at the back of the arm pad into the tab on the arm plate and rotate the arm pad down.

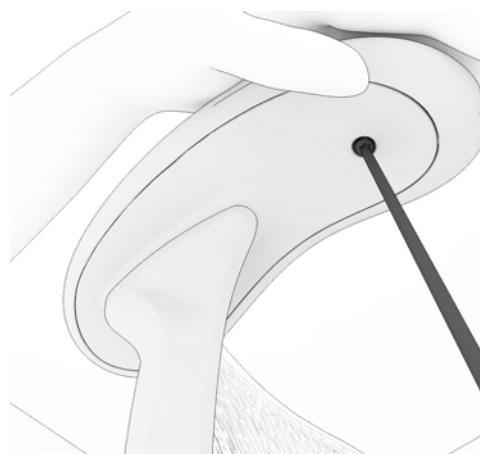

14. Torque to 15 in/lbs.

HermanMiller

Part no. 1BBSF4 rev D.

© 2014 Herman Miller, Inc. Zeeland, Michigan. Printed in the U.S.A.
©  HermanMiller, Mirra 2 are among the registered trademarks of Herman Miller, Inc.

Illustrations and specifications are based on the latest product information available at the time of publication. The right is reserved to make changes in design and specifications at any time, without notice, and also to discontinue products.