



New Aeron® Adjustable Arm Casting Replacement

Parts Included:



Adjustable Arm Casting



Bushing



Adjustable Arm Attachment Hardware Assembly



Lever Assembly

Tools Required:

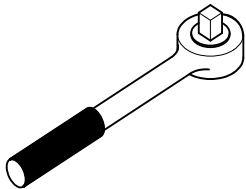

Ratchet Wrench

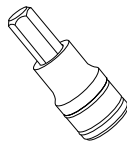

M5 Hex Bit

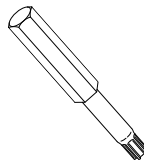

T27 Torx Bit

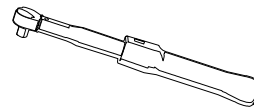

Torque Wrench

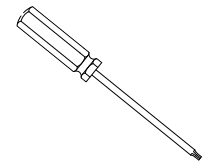

T27 and T25 Torx Driver

Steps:



1. Remove the back bolts using 5mm Hex bit.



2. Remove four bolts.



3. Detach the back from the chair.



4. Remove the screw to detach the arm pad for adjustable arm. Use T25 Torx bit to remove the screw.

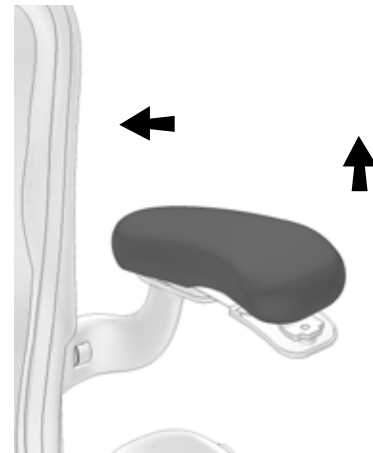

5. Lift the pad on the front and slide backwards as shown above to disengage it from the arm support.

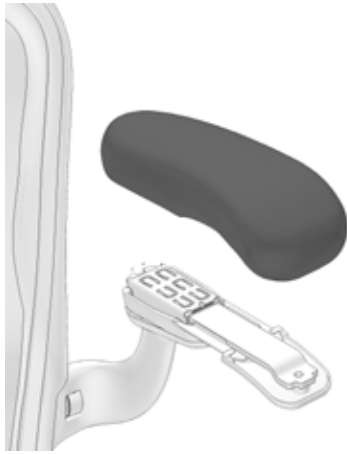

6. Detach the arm pad.



7. Note that the filler plate will get detached while removing the arm pad.



8. Slide the slide bar out of the arm support hardware assembly.

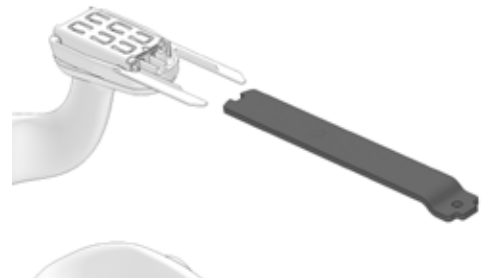



9. Insert the flat screw driver between the middle plate and the plastic housing and lift the plate up on both sides to detach the cover.

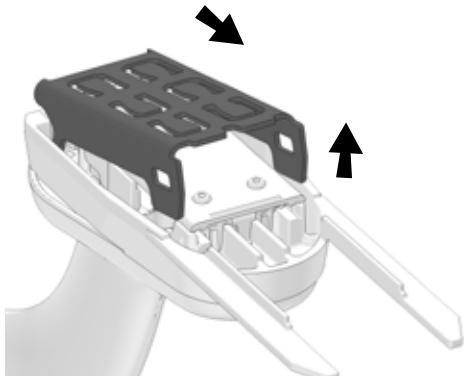

10. After releasing the metal plate, rotate the front part and pull out the metal plate outwards to disengage.

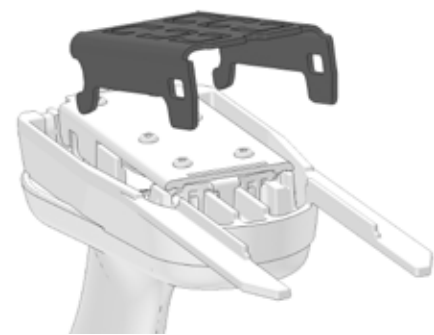

11. Detach the metal plate.

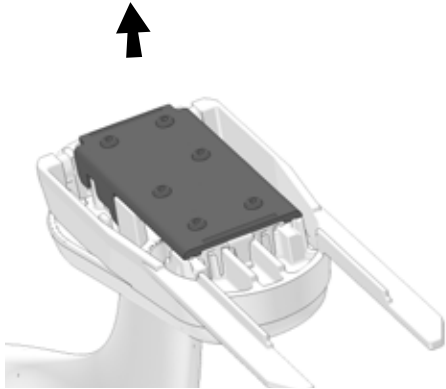

12. Remove the friction plate from the hardware assembly.



13. Remove the screw to detach the hardware assembly.



14. Use T27 Torx bit to remove the screws.

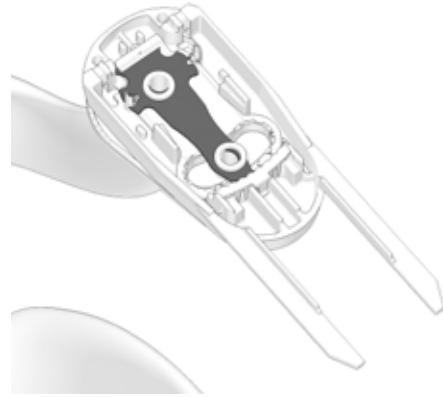

15. Remove the pivot plate.

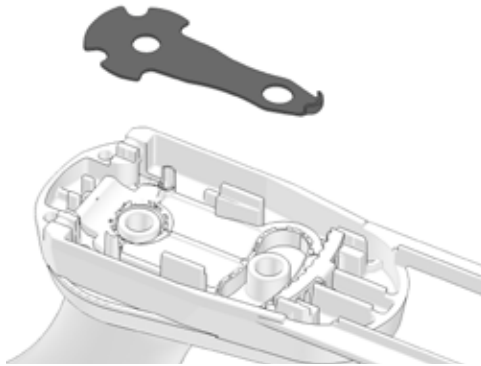

16. Detach the bottom cover.

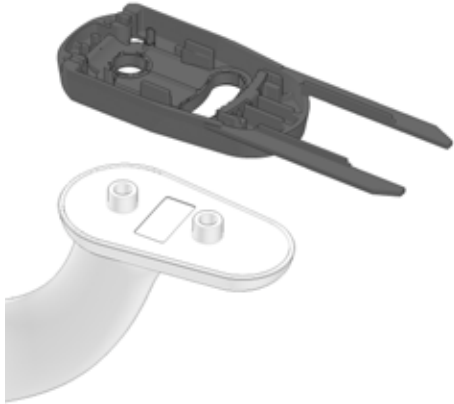

17. Detach the friction pad.



18. Detaching adjustable arm casting from the swing arm.

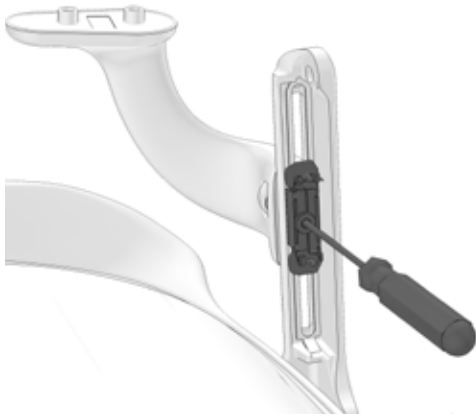

19. Remove the bolt from the swing arm using T27 torx driver.



20. Detach the arm and hardware attachment assembly. Note: Right hand arm shown has RH threads and a yellow bolt. The left hand arm has LH threads and a black bolt.



21. Remove the steel strip.

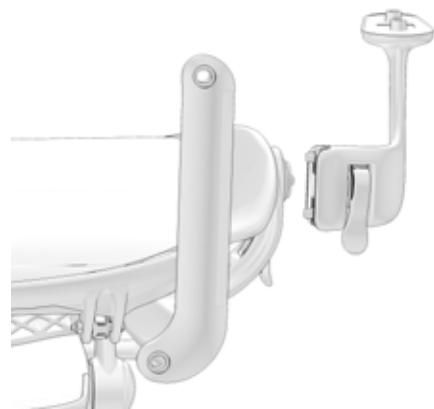

22. Detach the arm casting.

Re-Assembly Steps:



23. Place the lever assembly into the socket.



24. Attention: Lever should be in fully locked position during installation.



25. Attach the clip in the arm slot as shown.





26. Place the steel strip in place.

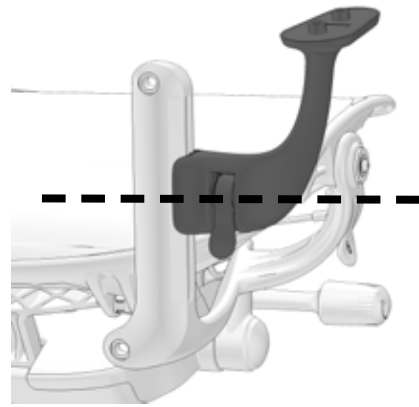

27. Install the arm assembly into the swing arm.
Attention: Keep the arm in vertically centre with the swing arm.



28. Install the hardware assembly as received.
Attention: Do not open the assembly. Follow the above orientation if sub-assembly is disoriented.

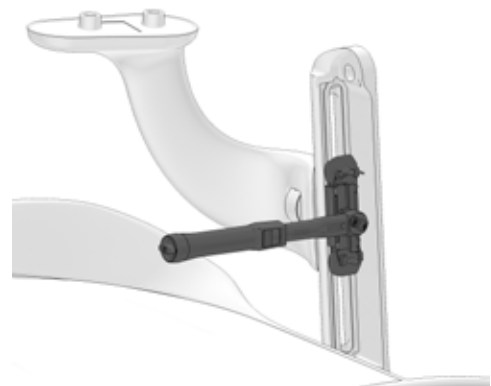

29. Install the bolt with 35 in-lbs torque using T27 torxbit.
Attention: Right hand arm shown has RH threads and a yellow bolt.

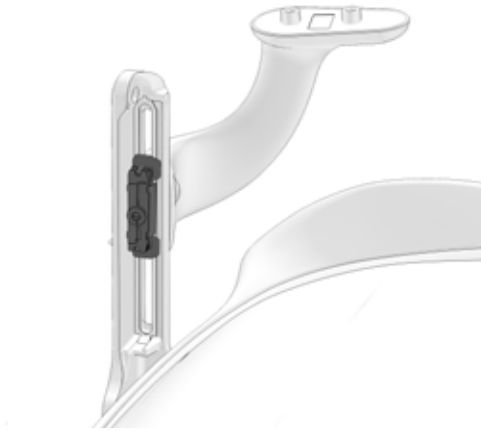

30. Follow previous steps to install left hand arm.
Attention: Left hand arm has LH threads and a black bolt.



31. Replace the friction pad in place.



32. Replace the hardware casing in place.

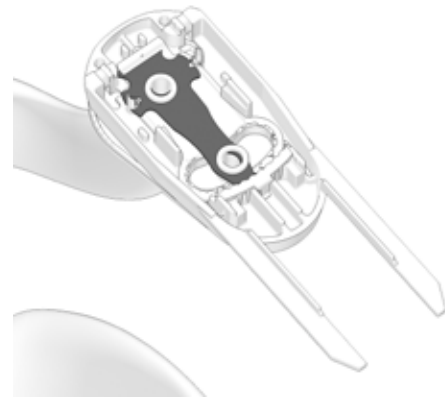

33. Place the pivot plate in place.



34. Tighten the screws using the T27 torx wrench. Torque each screw to 110 in-lbs.

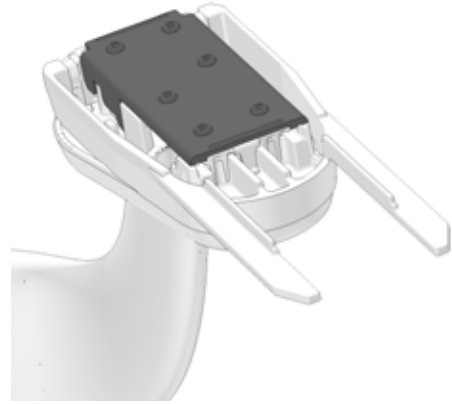

35. Replace the friction plate.

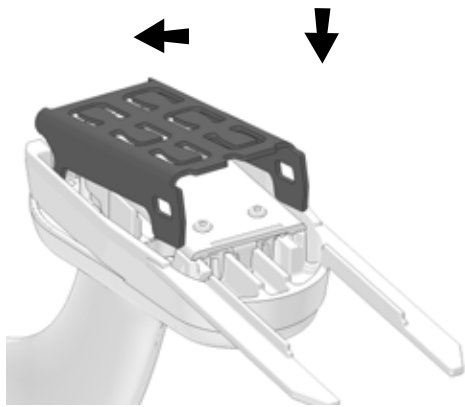

36. Hook the rear legs under the back on the plate and push down the front until it snaps.





37. Slide the slide bar inside the slot.
Note: The curve end has to face downwards.



38. Slide the filler plate in place.

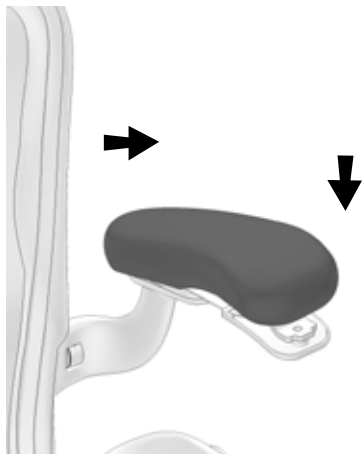

39. Slide the rear of the arm pad pocket over tab on arm support. Rotate front of arm down into position.



40. Align the filler plate hole with the slider bar. Use T25 torx bit to install the screw.



41. Install back assembly.



42. Install four back bolts using a torque wrench and a 5 mm hex bit. Torque each bolt to 150 in-lbs.