



Parts Included:



Cylinder

Tools Required:



Nylon Cap

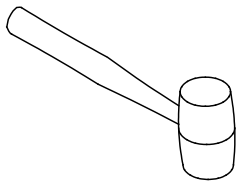

2#-3# Plastic Covered
Dead Blow Hammer

Note: Mirra 2 stool shown. For work chair omit footrest removal procedure.

Steps:

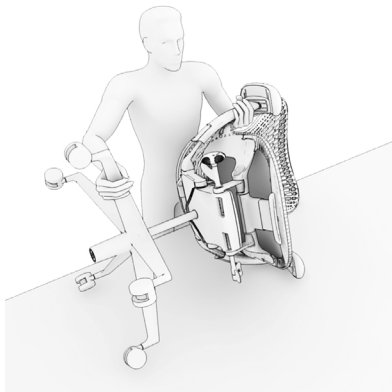

1. Lay chair on the side.

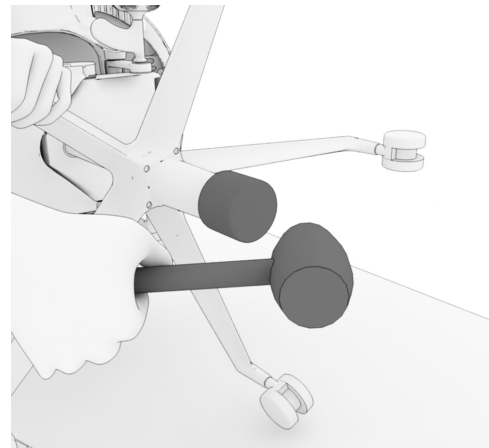

2. Place the nylon cap at the bottom of the cylinder. Using a dead blow hammer hit the bottom of the base.

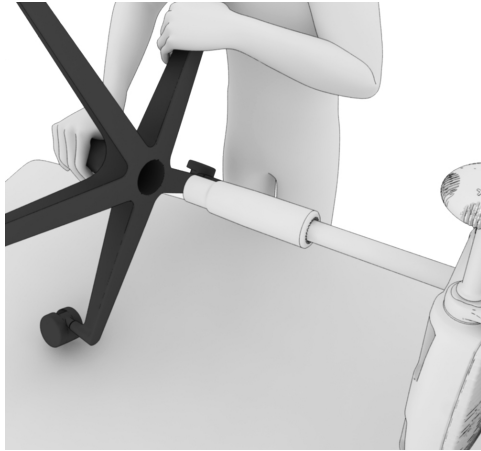

3. Remove base from the cylinder.

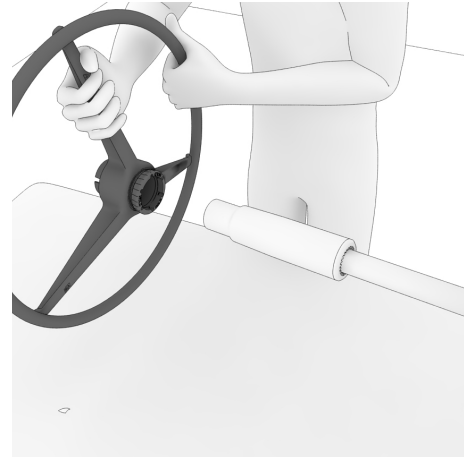

4. Remove footring from the cylinder.

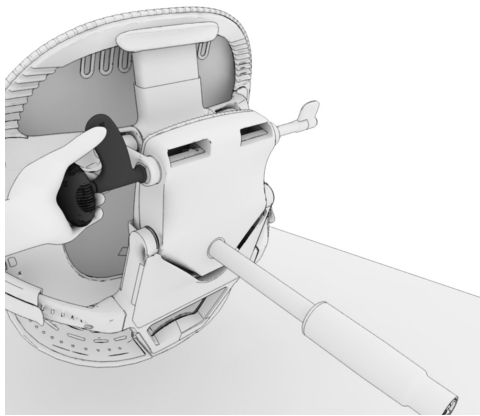

5. Rotate the height adjustment knob anti-clock wise to activate the cylinder.

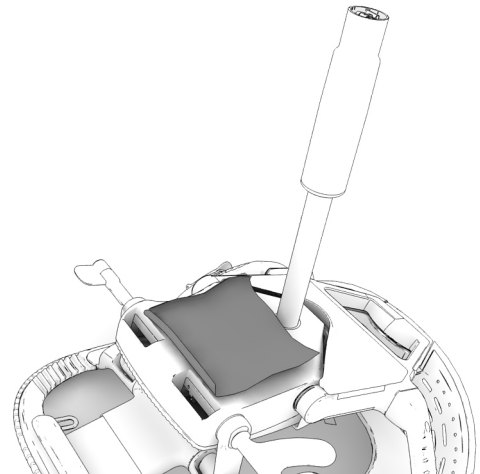

6. Place soft cloth onto tilt.

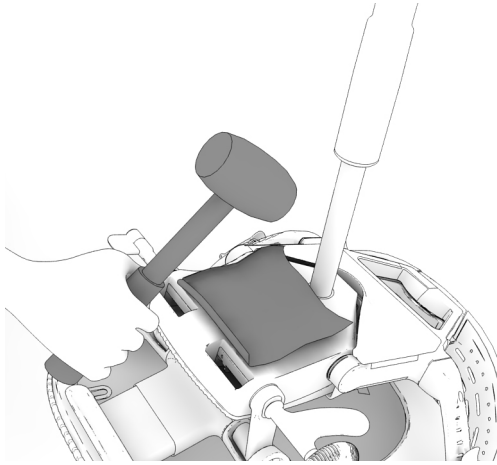

7. Strike the tilt with dead blow hammer back-and-forth on both sides until gas cylinder separates from tilt.

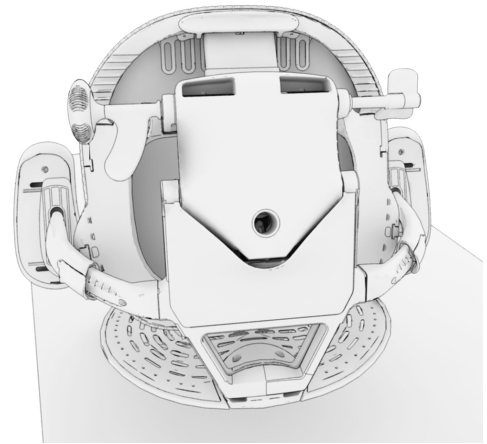

8. Remove the cylinder from the base.

Re-assembly Steps:

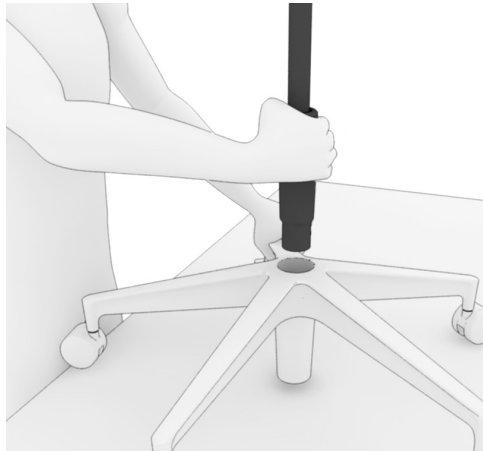

10. Install the new cylinder onto the base.

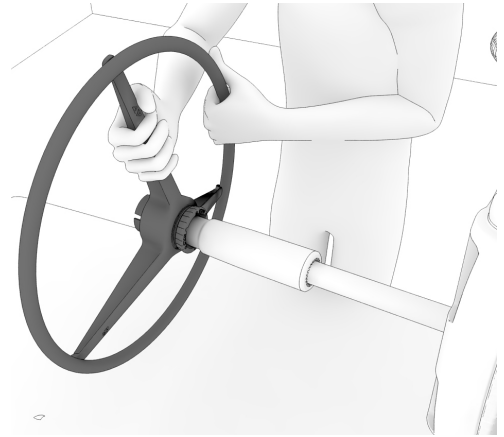

11. Install the footring into the cylinder.



12. Extend chair arms in upright position. Grab the arm stems and lower upper seat assembly onto top of cylinder.



13. Sit on chair firmly several times to set cylinder and base.

HermanMiller

Part no. 1BBT3D rev E.

© 2014 Herman Miller, Inc. Zeeland, Michigan. Printed in the U.S.A.
™ and Compass are among the trademarks of Herman Miller, Inc.

Illustrations and specifications are based on the latest product information available at the time of publication.
The right is reserved to make changes in design and specifications at any time, without notice, and also to discontinue products.